

Uniformity of Monkey Striate Cortex: A Parallel Relationship between Field Size, Scatter, and Magnification Factor

DAVID H. HUBEL AND TORSTEN N. WIESEL
*Department of Neurobiology, Harvard Medical School, 25 Shattuck Street,
Boston, Massachusetts 02115*

ABSTRACT This paper is concerned with the relationship between orientation columns, ocular-dominance columns, the topographic mapping of visual fields onto cortex, and receptive-field size and scatter. Although the orientation columns are an order of magnitude smaller than the ocular-dominance columns, the horizontal distance corresponding to a complete cycle of orientation columns, representing a rotation through 180° , seems to be roughly the same size as a left-plus-right ocular dominance set, with a thickness of about 0.5–1 mm, independent of eccentricity at least out to 15° . We use the term *hypercolumn* to refer to a complete set of either type (180° , or left-plus-right eyes).

In the macaque monkey several penetrations were made at various eccentricities in various parts of the striate cortex subserving the fovea, parafovea and midperiphery. As observed many times previously, in any vertical penetration there was an apparently random scatter in receptive-field positions, which was of the same order of magnitude as the individual receptive fields in that part of the cortex; the field size and the scatter increased in parallel fashion with eccentricity. The movement through the visual field corresponding to a 1 mm horizontal movement along the cortex (the reciprocal of the magnification factor) also increased with eccentricity, in a manner that was strikingly parallel with the increase in receptive field size and scatter. In parts of the cortex representing retina, at least out to about 22° from the fovea, a movement along the cortical surface of about 1 mm was enough to displace the fields so that the new position they collectively occupied half overlapped the old. Such an overlap was thus produced by moving along the cortex a distance about equal to the thickness of a left-plus-right set of ocular-dominance columns, or a complete 180° array of orientation columns. It therefore seems that, independent of eccentricity, a 2 mm \times 2 mm block of cortex contains by a comfortable margin the machinery needed to analyze a region of visual field roughly equal to the local field size plus scatter. A movement of 2–3 mm corresponds to a new visual field region and to several new sets of hypercolumns. The cortex thus seems remarkably uniform physiologically, just as it is anatomically.

As a recording electrode moves through the monkey striate cortex in a direction parallel to the surface, the position in the visual fields from which responses are evoked changes in a predictable manner, according to a systematic topographic map (Talbot and Marshall, '41; Daniel and Whitteridge, '61). Engrafted on this projection of the visual fields are two columnar systems, one subserving receptive-field orientation, the other, ocular dominance. In the preceding paper (Hubel and

Wiesel, '74) we showed that changes in orientation with tangential movement occur in a highly systematic manner, in small, relatively constant steps of at most about 10° . These orientation columns apparently have the form of parallel slabs, with a thickness of 25–50 μ or less. We had found in a previous study that the ocular-dominance columns are likewise slab shaped, with a thickness of 0.25–0.5 mm (Hubel and Wiesel, '72). Over the regions of cortex so far examined the di-

mensions of both column types are roughly constant, a result that is not unexpected given the relative histological uniformity of the striate cortex.

From a different standpoint, however, this relative constancy of column size over the cortex seemed surprising, since it is known that the number of degrees of visual field corresponding to 1 mm movement along the cortex (the reciprocal of the magnification factor) is far from constant, being small for the foveal representation and larger — by a factor of about 35 — for the periphery. Both receptive-field size and scatter in the field positions of neighboring cells are likewise small in the foveal region and large in the periphery. The present paper addresses itself to resolving this apparent inconsistency between a relatively constant histological appearance and column size, on the one hand, and a markedly inconstant magnification and field size, on the other. The crux of the problem turns out to lie in the exact relationship between field size, field scatter, and magnification, as position in the cortex (or in the visual field) is varied. Our conclusion is that the cortex is, after all, a remarkably uniform structure.

METHOD

Seven penetrations were made in two normal adult rhesus monkeys. In all, 125 cells were studied. Methods of recording and stimulating were generally the same as in previous studies (Hubel and Wiesel, '68, '74). Since in estimating field scatter and magnification¹ it was important to determine the positions of receptive fields precisely, we used an eye-monitoring technique originally devised for measurements of retinal disparity (Hubel and Wiesel, '70). Cells were recorded in the usual way with an electrode in one hemisphere, and eye positions were monitored by recording from a single binocular cell for long periods with a second electrode placed in the opposite striate cortex; after recording from each new cell with the main recording electrode we quickly checked eye positions by switching the input stage to the reference electrode and re-mapping the receptive fields of the reference cell. Electrodes were selected to be fine enough to resolve single units easily, but coarse

enough so that there was a reasonably high likelihood of dual-unit recordings.

RESULTS

In our previous work in cats ('62) we observed an apparently random variation in receptive-field position on recording from successive cells during a penetration perpendicular to the cortical surface. The amount of variation in receptive-field position was such that the total visual-field area covered by the superimposed receptive fields in one penetration was several times the area occupied by a single field; most of the fields either overlapped or abutted each other. In a long tangential penetration, a gradual drift in field positions was superimposed on the random scatter, but electrode movements of a few tenths of a millimeter were far too small for this drift to be apparent. We concluded that there are limitations to the precision of the topographic map of visual fields on to cortex.

In the monkey we have had the strong impression that the organization is similar, but we wished to re-examine the problem in order to learn more about the relationship between receptive-field size and amount of scatter on the one hand, and topography on the other. The first step was to record from enough cells in a perpendicular penetration, in a particular region of monkey cortex, to form an idea of the range of receptive-field sizes and the amount of scatter. We monitored eye movements with a second electrode to be absolutely sure that the scatter was real (METHODS).

In the perpendicular penetration of figure 1, the receptive-field positions of 14 consecutively recorded cells are superimposed. The penetration was made about 15 mm behind the lunate sulcus and 10 mm to the left of the midline, corresponding to a visual-field area 10° to the right of the fovea and 1–2° above it. The track ended in layer IV B, 1.3 mm from the surface. All cells were strongly dominated by the right (contralateral) eye. As expected, the fields overlapped exten-

¹ *Note on magnification factor:* This term refers to millimeters of cortex corresponding to 1° of visual field (Daniel and Whitteridge, '61). The reciprocal of this index was found more useful in the present study. We designate it as "magnification⁻¹." "Eccentricity" refers to distance from fovea, in degrees.

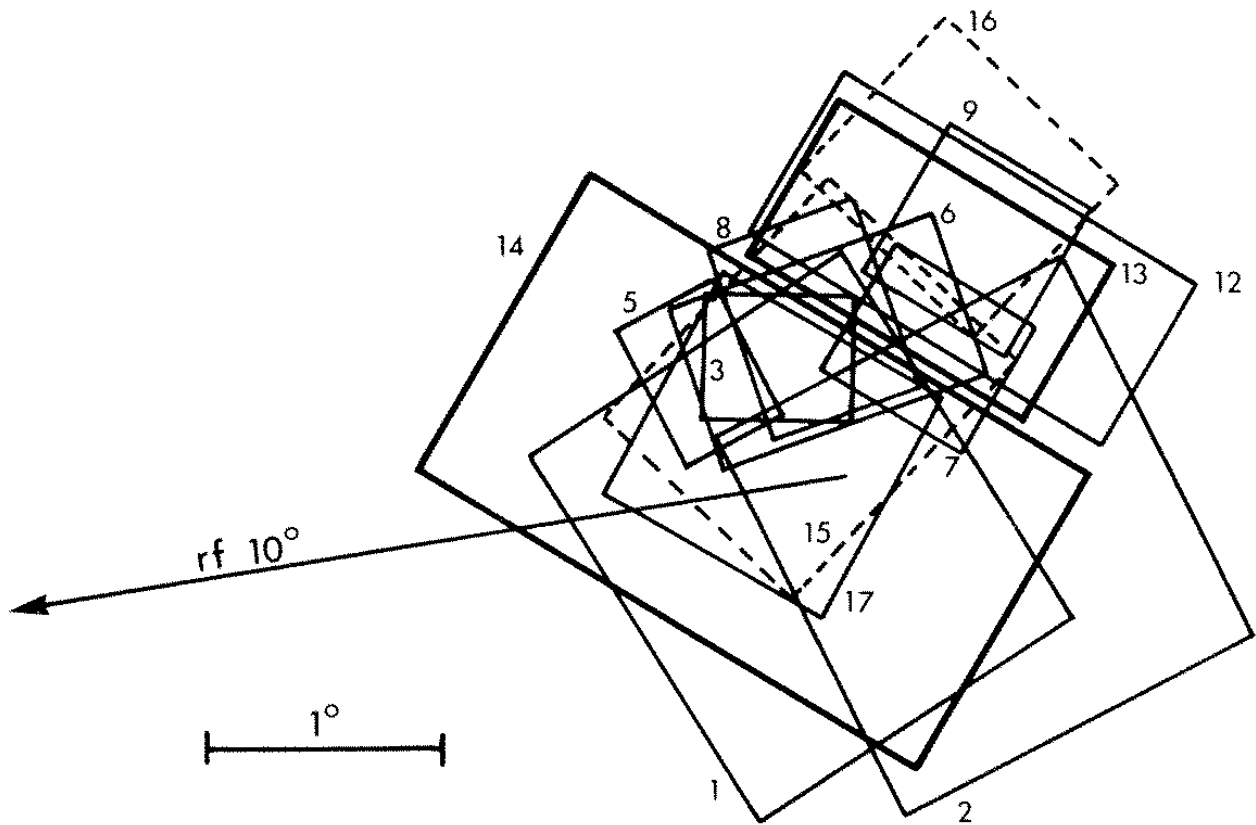

Fig. 1 Scatter of receptive fields in a perpendicular penetration. Receptive-field positions of 14 consecutively recorded cells from monkey striate cortex 10 mm to the left of the midline and 15 mm behind the lunate sulcus. The fields, mapped in the right eye, were 10° from the right fovea, just above the horizontal meridian. Fields 13 and 14 (heavy lines) are mapped for simultaneously recorded cells, as are fields 15 and 16 (interrupted lines). Eye positions are monitored with a reference electrode in the left striate cortex by repeatedly checking receptive-field positions of a binocular cell. The scatter, relative to the receptive-field size, is typical for area 17.

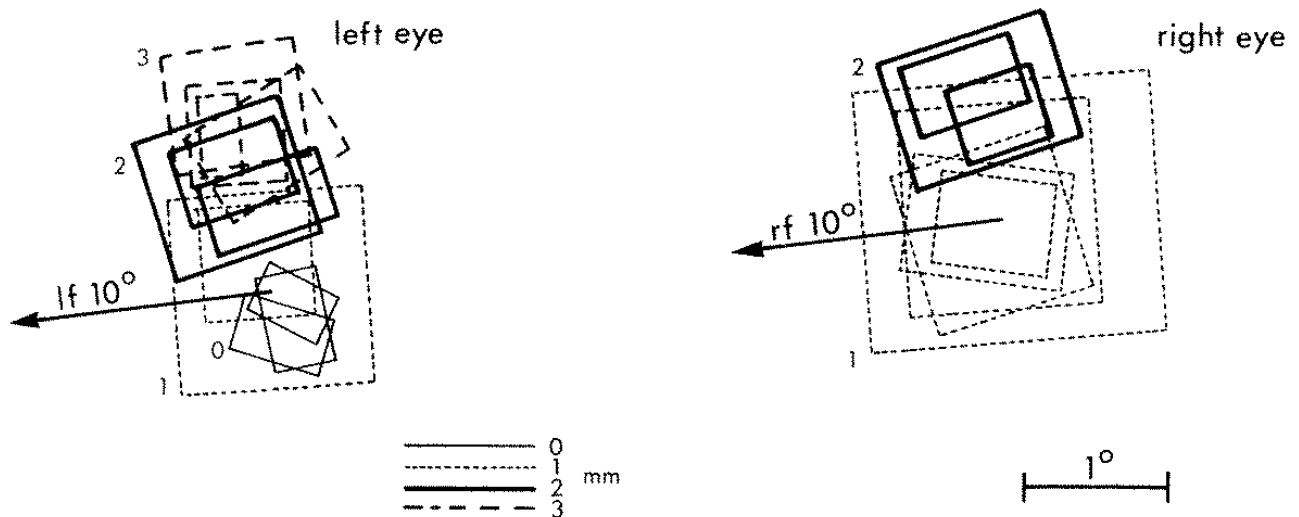

Fig. 2 Relationship between receptive-field size-plus-scatter and magnification for an eccentricity of 10°. Same monkey as in figure 1, same region of cortex. In a penetration making an angle of 30° to the cortical surface, the fields of several cells were mapped in the first 0.1 mm and the electrode was advanced 900 μ . This procedure was repeated until white matter was reached. In this figure the first cluster of fields, marked "0," is drawn with thin continuous lines; the second, marked "1," with dots, and so on. Note the alternation of eyes as the electrode passed through successive ocular-dominance columns.

sively, and the total size of the region through which the fields were spread (about $4^\circ \times 4^\circ$) was several times the average size of the individual fields (about $1.3^\circ \times 1.3^\circ$). Two pairs of simultaneously recorded cells are indicated, one by heavy lines (13, 14) and the other by interrupted lines (15, 16). In both pairs the fields are certainly not superimposed and in fact hardly overlap, but instead come into contact along one border: such a degree of separation in the receptive fields of neighboring cells is not unusual, though it is more common to find some overlap. Simultaneous recordings such as these supply additional evidence that the scattering is real and not an artifact produced by eye movements. The relationship shown in this figure between overlap and scatter is typical of what we have seen in all perpendicular penetrations in striate cortex.

Our next step was to determine the number of degrees of visual field corresponding to a 1 mm horizontal movement along this part of the cortex, i.e., magnification⁻¹. To do this we inserted the electrode into the same cortical area but tilted it so as to penetrate in a posterior direction, making as acute an angle to the surface as feasible ($30\text{--}35^\circ$). We first

mapped the fields of whatever cells were within recording distance by stopping to stimulate and record each $20\ \mu$ for the first $100\ \mu$. We then quickly advanced the electrode $900\ \mu$. The whole procedure was repeated, mapping out four or five fields over the next $100\ \mu$ and advancing a further $900\ \mu$. In this way a group of fields was plotted roughly every millimeter until after four groups (a distance of 3 mm) white matter was reached. The results are shown in figure 2. Several shifts in eye dominance were seen, as expected for a movement of this length: cells were influenced first by the left eye only, next by both eyes with the right eye strongly dominant, then by the two eyes equally, and finally once more by the left eye only. Thus the 3 mm penetration cut through at least three eye-dominance columns. At each advance of 1 mm there was a displacement of the mean field position upwards in the visual field, as expected from the known topography. Each displacement was roughly the amount required to produce a 50% overlap between the new territory over which the fields were scattered, and the old. Allowing for the electrode inclination (30°), the value of magnification⁻¹ corresponding to

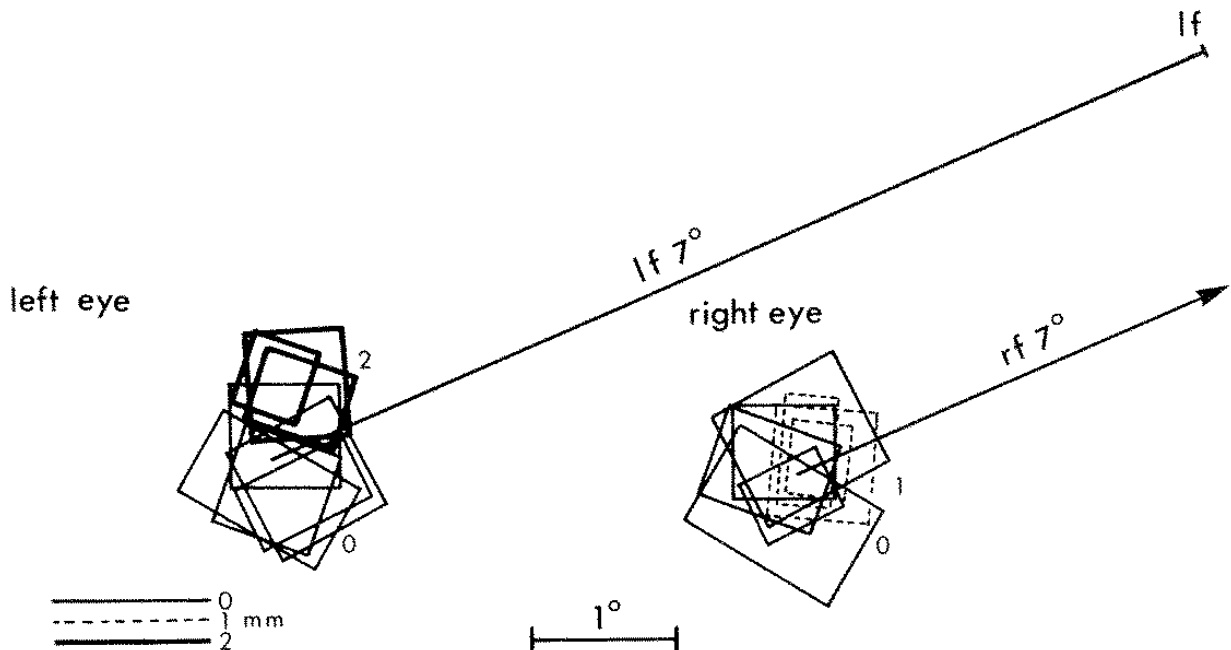

Fig. 3 Relationship between field size-plus-scatter and magnification, for a 7° eccentricity. Same monkey as in figures 1 and 2, right hemisphere. Angle between electrode track and surface of cortex, 30° . Scale is the same as in figure 2. Note the decrease in field size and scatter and in the displacement in position with each 1 mm advance of the electrode.

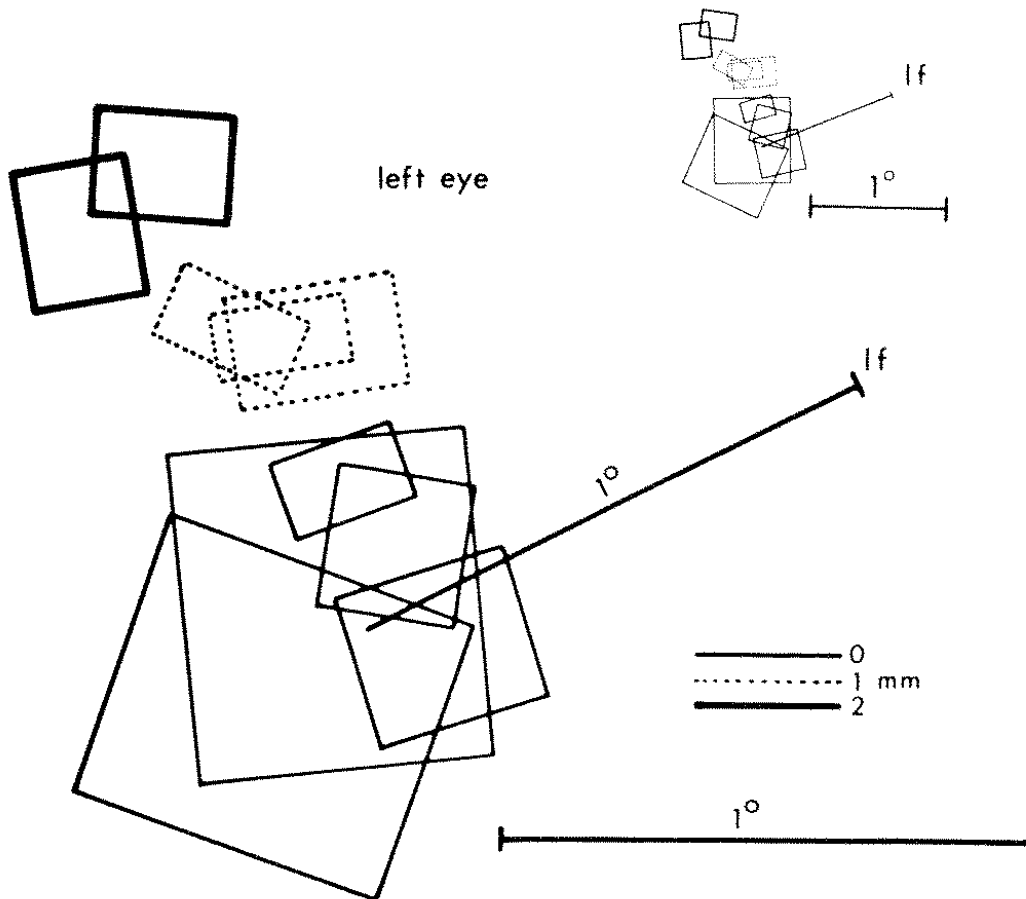

Fig. 4 Relationship between field size-plus-scatter and magnification, for a 1° eccentricity. Here the scale of the figure is about four times that of figures 2 and 3, but the inset shows the same diagram reduced to match figures 2 and 3. Different monkey from that of figures 1-3. Angle of electrode to surface, 5°.

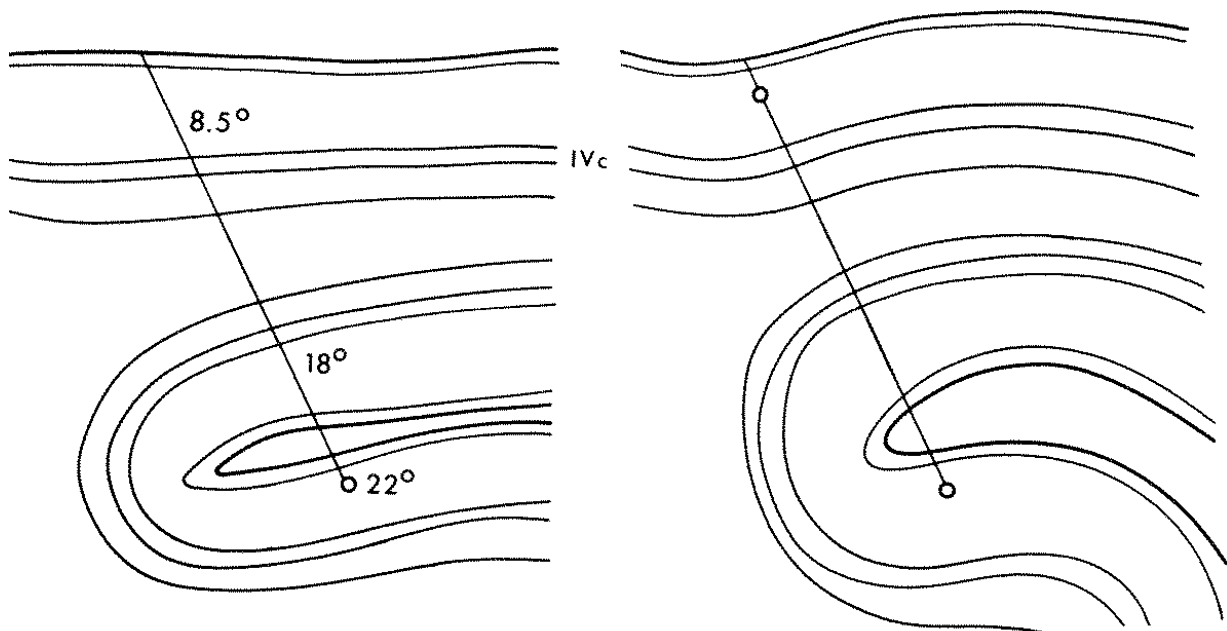

Fig. 5 Reconstruction of two electrode tracks, in two parasagittal planes 3 mm apart. Eccentricity for the surface traverse, 8.5°; for the two folds of the calcarine fissure, 18° and 22°. The results were used in plotting the 8.5°, 18° and 22° points in figure 6A.

this eccentricity of 10° was estimated to be $0.65^\circ/\text{mm}$.

A similar experiment was done in the same monkey for a region of the right striate cortex slightly further lateral and anterior, subserving a visual-field territory 7° from the fovea instead of 10° . From the results shown in figure 3, allowing for electrode obliquity, it can be calculated that 1 mm represents about 0.5° in the visual field. As expected, both the receptive fields and the scatter were now smaller. Thus in both penetrations a 1 mm movement through the cortex produced a shift of receptive-field positions that was large enough to be obvious above the random staggering, but still small enough so that the two sets of fields overlapped.

The same procedure was repeated in two more monkeys, in regions with eccentricities of 1° and 4° . The diagram for 1° is shown in figure 4. From the inset,

which is the same diagram drawn to the scale of figures 2 and 3, it can be seen that the fields and scatter are now much smaller, and so is the field displacement corresponding to each millimeter of movement. Magnification $^{-1}$ was calculated to be $0.25^\circ/\text{mm}$.

For more peripheral penetrations a different strategy had to be adopted, since this part of the cortex is buried deep in the calcarine fissure and tangential penetrations are impractical. We therefore first made a long parasagittal penetration (same monkey as that of the 4° penetration) through the convexity (8.5°) and through two folds of the buried calcarine cortex (18° and 22°). A second penetration was then made parallel and 3 mm lateral to the first. The two tracks are reconstructed in figure 5. As expected, the three field positions were now slightly displaced. Each time a thickness of cortex

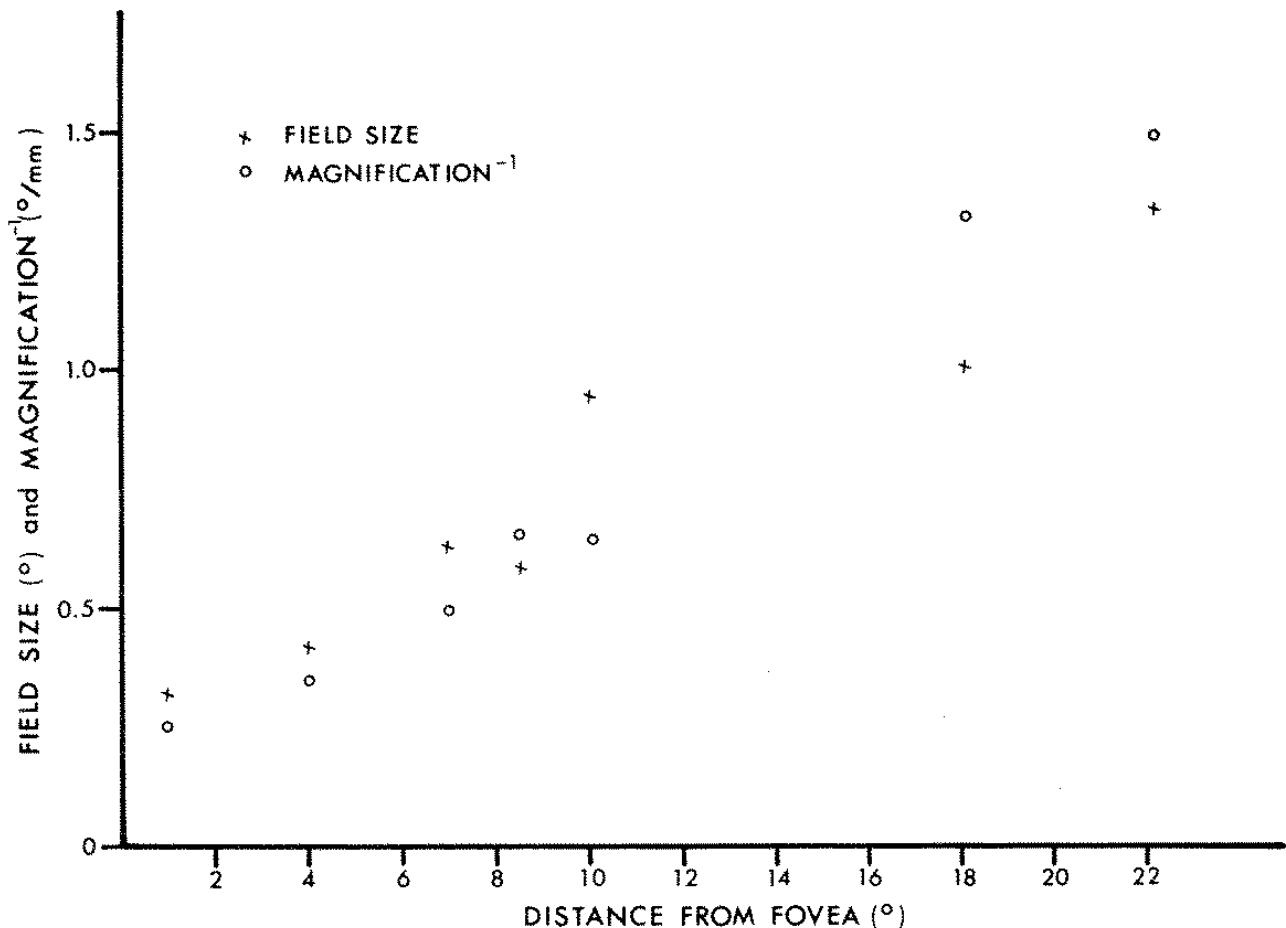

Fig. 6A Graph of average field size (crosses) and magnification $^{-1}$ (open circles) against eccentricity, for five cortical locations. Points for 4° , 8° , 18° and 22° were from one monkey; for 1° , from a second. Field size was determined by averaging the fields at each eccentricity, estimating size from $(\text{length} \times \text{width})^{0.5}$.

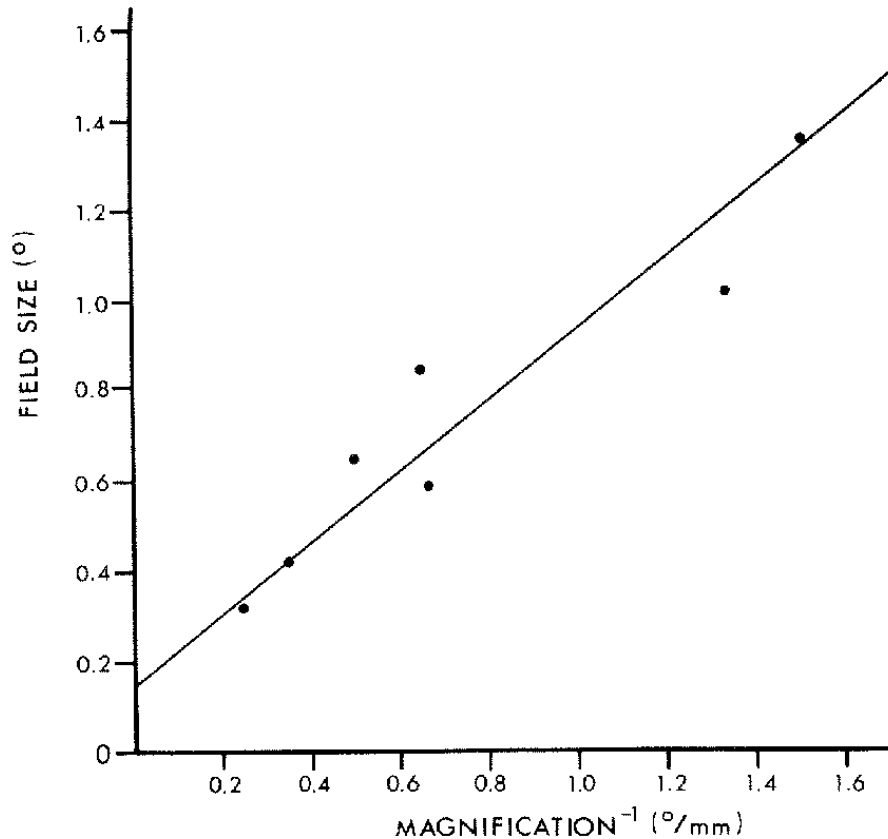

Fig. 6B Graph of field size vs. magnification⁻¹, using the values from figure 6A.

was traversed, four–six fields, on the average, were mapped. Thus for each of three field positions the average field size could be determined, and magnification⁻¹ obtained by dividing the field displacements by three.

The results of all seven determinations are shown in figure 6A, in which we plot magnification⁻¹ (open circles) and field size (crosses) against distance from fovea. As a measure of field size we took (length \times width)^{0.5}. Given the smallness of the samples and the large variation in field size at each eccentricity (figs. 1–4), it is perhaps surprising that the graph of field size vs. eccentricity is not more chaotic than it is. Cells in layer IV C, whose fields are very small, were excluded from the series, but in an exhaustive study of field size one would have to consider cells layer by layer. Despite this difficulty the graph confirms our expectation that field size and magnification⁻¹ change with eccentricity in strikingly parallel fashion, at least as far peripheral as 22°.

Figures 2–4 suggest that magnification and receptive-field size are roughly pro-

portional. In figure 6B this is confirmed by plotting a graph of field size against magnification⁻¹, using information from the graph of figure 6A.

Figure 7 sums up these results by showing a single cluster of fields from each of the 1°, 7° and 10° penetrations in relation to the fovea (f). For each pair of circles the two members are separated by a distance corresponding to a 1 mm movement along the cortex (i.e., by a distance equal to "magnification⁻¹") so that magnification and field size-plus-scatter can be compared directly. As eccentricity increases so does the distance between circles in each pair (magnification⁻¹), and parallel with this there is a corresponding increase in the area taken up by each cluster of receptive fields.

DISCUSSION

Central to the concept of the cortical column is the idea of a group of cells with one common physiological characteristic, such as a particular value of some variable. The cells behave as though they shared certain connections among them-

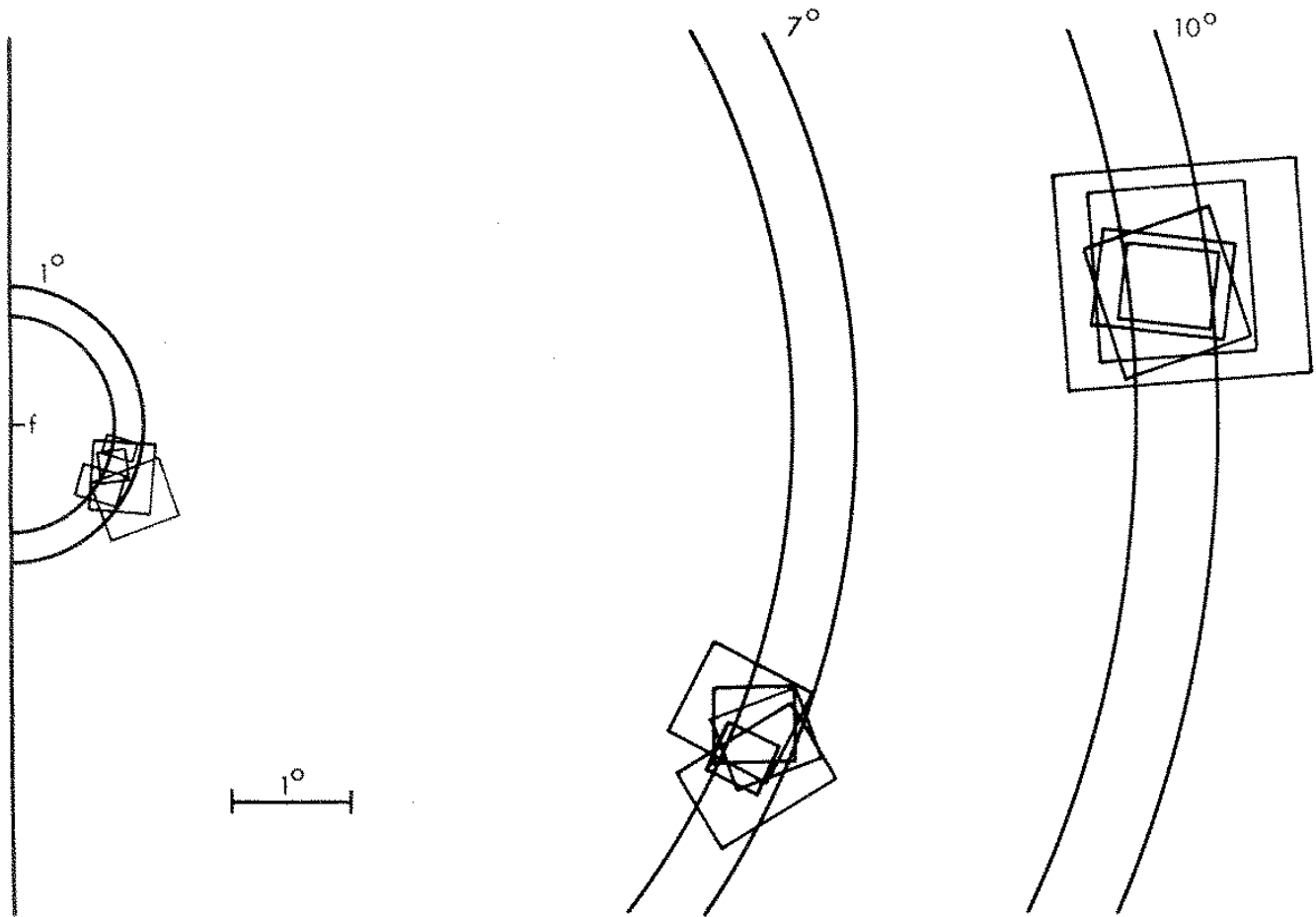

Fig. 7 Relation between field size-plus-scatter and magnification, for three different eccentricities, 1° , 7° and 10° . The diagram shows part of the right field of vision, with vertical meridian and fovea (f) represented on the extreme left. Three clusters of receptive fields are redrawn from figures 2, 3 and 4; each represents the fields mapped in a 0.1 mm segment of penetration. (For economy of illustration, the 1° and 7° groups of fields, which were actually in the left visual field, have been mirror-reversed.) Each pair of concentric circles is drawn so that the difference in the two radii equals magnification $^{-1}$ for that eccentricity.

selves, but not with cells of neighboring columns, and in this sense a single group of cells is looked upon as a more or less autonomous functional unit. If the variable has only two values, as is so for the somato-sensory columns described by Mountcastle ('57) or for the ocular-dominance columns, then on moving horizontally across the cortical surface the values of the variables must obviously simply alternate, from one eye to the other, for example. If the variable can have many values, as in the orientation columns, one can expect either an ordered sequence or a random one. In the preceding paper (Hubel and Wiesel, '74) the chief finding was that the orientation columns are arranged with great regularity, so that a probe moving along the cortex horizon-

tally may generally be expected to encounter all values of orientation (roughly 18–20) in regular sequence before any one value is repeated.

Given this result, it seems useful to extend the concept of the column, and consider a complete array of columns as a small machine that looks after all values of a given variable. For the orientation system this would be a full set of slabs subserving an entire 180° cycle, while for the ocular dominance system it would be a left-eye column plus a right-eye column. We may refer to such a group as a *hyper-column*.

We had long been puzzled by the observation that ocular-dominance columns are 0.25–0.5 mm wide, and therefore an order of magnitude larger than the orientation

columns. Only on seeing the orderliness of the orientation columns did we realize that there is a close similarity in *total* width between an array of orientation slabs that takes in all 180° of orientation, and a left-plus-right set of ocular-dominance columns. Both of these amount to something like 0.5–1 mm. That the two kinds of hypercolumns are of the same order of magnitude may not be purely coincidence, for the size itself must be of some importance. Suppose, for example, that orientation columns were so large that in going through a large angle, say 90° , the distance along the cortex corresponded to a considerable movement in the visual field. The result would be bizarre indeed: the animal would be sensitive to horizontal lines in one part of its visual field, to various obliques in others, and to verticals in still others. A similar problem would arise with respect to eye preference — the visual fields would be carved up into a mosaic of left-eye and right-eye areas, with each eye seeing only its own subdivisions. But it has been clear since our '62 paper that the precision of cortical representation holds only down to a certain size of cortical surface, and only down to a certain area of visual field. Cells in a given cortical region have finite sized receptive fields and a finite (and proportional) random variation in position; a certain constant distance along the cortex, amounting to 2–3 mm, must be traversed in order to obtain a shift in field position comparable to the size of the fields plus their scatter. Within such a distance one can have many subregions subserving different orientations of receptive fields, or subregions dominated first by one eye and then by the other, without getting into difficulties related to topography. It is remarkable that this distance is about the same as the size of the hypercolumns — it would be more accurate to say that it is about double or triple, since roughly a 2–3 mm displacement is required to get out of one region of visual field and into an entirely new one, as compared with 0.5–1 mm for the widths of the hypercolumns. In a sense, then, a 2–3 mm region of cortex can be said to contain by a comfortable margin the machinery it needs to analyze the region of visual field that it subserves. It is prob-

ably significant that 2–3 mm is also roughly the horizontal distance over which cortical cells are interconnected (Fisken et al., '73).

The relationship seems to hold throughout the visual cortex, for everywhere the columns, and hence the hypercolumns, are probably about the same size and, at least over the region explored, the span of cortex corresponding to the local receptive-field size plus scatter seems to be constant. The receptive-field size plus associated scatter varies tremendously over the cortex, but so does the visual-field area corresponding to 1 mm of cortex. The degree to which these are matched is striking and surely no accident.

Thus the machinery may be roughly uniform over the whole striate cortex, the differences being in the inputs. A given region of cortex simply digests what is brought to it, and the process is the same everywhere. Certainly this general idea is not refuted by any striking histological non-uniformity over the visual cortex, from fovea to far periphery. If it is assumed that the number of optic-radiation fibers entering a square millimeter of cortex is roughly constant (Clark, '41) then differences from one region to the next must simply be related to the size of the geniculate receptive fields and their scatter.

Another example of this stereotyped processing of input can be seen on comparing striate cortex of normal and Siamese cats (Hubel and Wiesel, '71). The 17–18 border region in the ordinary cat subserves the visual-field midline, whereas in one type of Siamese cat the seemingly identical area, morphologically, serves a region 20° in the ipsilateral periphery, where the fields and scatter are much larger. Apparently this segment of cortex can carry out the same operation on the two widely differing sets of inputs. The capability is evidently an intrinsic property of the cortex, depending on genetically determined connections and not on post-natal experience, since the topography is the same in Siamese kittens whose eyes have been closed since birth.

This is not to deny the possibility of certain non-uniformities over the cortex — indeed regional differences are to be expected, given the relative preoccupation

of the central visual fields with form and color, of the periphery with scotopic vision and movement, and the absence, in the far periphery, of binocular interaction. It would be surprising if careful studies even of such crude indices as cortical thickness failed to reveal differences between foveal and peripheral representations. The point here is that if differences in histology exist they are not so glaring as to be obvious at a glance and are certainly minor when one considers the 30–40 fold variation in magnification factor.

The tasks that a given region of cortex must fulfill are many and varied and include the machinery for establishing orientation specificity, directional selectivity, degree of complexity, selectivity to color, and binocular convergence, all for a particular region of visual field. It may be that there is a great developmental advantage in designing such a machinery once only, and repeating it over and over monotonously, like a crystal, for all parts of the visual field. The problem is to achieve the uniformity despite the great difference in detail of representation between central and peripheral visual fields.

How successfully the problem has been solved can be appreciated by comparing the relative uniformity of the cortex with the striking non-uniformity of the retina. The ganglion-cell layer of the monkey retina, for example, is some five cells deep near the fovea, whereas in the far periphery there are not enough cell bodies to make up one continuous layer (Van Buren, '63). For simple reasons of optics, the retina cannot adopt the strategy that the cortex employs; if the retinal surface must be spherical, the magnification factor has to be the same throughout, despite the difference in precision of representation between central and peripheral visual fields. Hence its histological non-uniformity. The cortex has no such arbitrary restrictions on surface shape. If the retina is mapped onto the cortex in such a way that magnification is at every point independent of direction and falls off with eccentricity, the resultant surface must be far from spherical. (If magnification is constant, the spherical retina obviously maps onto a sphere. If magnification falls off with eccentricity, one may imagine

building up the cortical surface by beginning at the foveal projection and adding on successive circular rings having the foveal projection as a common center. The circumference of each ring is the product of the circumference of the corresponding retinal ring and the magnification, so that a variation in magnification will produce distortion of the sphere.) In 1962 Daniel and Whitteridge modelled the striate cortex in rubber and smoothed out the folds so as to examine the overall shape. As expected, the surface was far from spherical and was roughly what was predicted from a knowledge of the magnification factor at every eccentricity. The distortion in the shape of the cortical surface can be regarded as a consequence of the need to keep the histology uniform.

Despite this marked difference between retina and cortex in histological uniformity, similar principles probably prevail in the two structures. In the cortex, magnification changes with eccentricity, while cell density remains roughly constant: in the retina, magnification is constant but ganglion cell density (cells/unit area) varies. If the field size of cortical cells is matched to the magnification, we may reasonably ask if field sizes of retinal ganglion cells are matched to cell density. Just such an enquiry has been made in the cat retina by Fischer ('73), who measured field-center sizes at different eccentricities and correlated the results with ganglion cell densities as estimated by Stone ('65). With increasing eccentricity receptive-field center areas increase (Wiesel, '60), but ganglion-cell density declines, and Fischer found that the two vary inversely, the average number of ganglion cells in a receptive field center having a roughly constant value of about 35 throughout the retina. The two sets of results, in retina and cortex, are probably equivalent, for in the cortex the counterpart of the retinal receptive field under which Fischer estimates cell numbers is the cortical projection of the boundaries of an average cortical receptive field. The present study shows that the cortical area so enclosed is constant (in fact, it is the square of the slope of the graph of fig. 6B, i.e., 0.66 mm²). If cell density in the cortex is roughly uniform the number of cells under this area will obviously be

constant. It would be of great interest to make an analysis similar to Fischer's in the monkey retina and in the geniculate, for comparison with the present results in the cortex.

ACKNOWLEDGMENTS

We wish to thank Sandra Spinks, David Freeman and Claire Wang for technical assistance. The work was supported by NIH Grants 5ROI EYO 0605 and 5ROI EYO 0606, and a grant from the Esther A. and Joseph Klingenstein Fund, Inc.

LITERATURE CITED

- Clark, W. E. LeGros 1941 The laminar organization and cell content of the lateral geniculate body in the monkey. *J. Anat., Lond.*, 75: 419-433.
- Daniel, P. M., and D. Whitteridge 1961 The representation of the visual field on the cerebral cortex in monkeys. *J. Physiol.*, 159: 203-221.
- Fischer, B. 1973 Overlap of receptive field centers and representation of the visual field in the cat's optic tract. *Vision Res.*, 13: 2113-2120.
- Fisken, R. A., L. J. Garey and T. P. S. Powell 1973 Patterns of degeneration after intrinsic lesions of the visual cortex (area 17) of the monkey. *Brain Res.*, 53: 208-213.
- Hubel, D. H., and T. N. Wiesel 1962 Receptive fields, binocular interaction and functional architecture in the cat's visual cortex. *J. Physiol.*, 160: 106-154.
- 1968 Receptive fields and functional architecture of monkey striate cortex. *J. Physiol.*, 195: 215-243.
- 1970 Cells sensitive to binocular depth in area 18 of the macaque monkey cortex. *Nature*, 225: 41-42.
- 1971 Aberrant visual projections in the Siamese cat. *J. Physiol.*, 218: 33-62.
- 1972 Laminar and columnar distribution of geniculate-cortical fibers in the macaque monkey. *J. Comp. Neur.*, 146: 421-450.
- 1974 Sequence regularity and geometry of orientation columns in the monkey striate cortex. *J. Comp. Neur.*, 158: 267-294.
- Mountcastle, V. B. 1957 Modality and topographic properties of single neurons of cat's somatic sensory cortex. *J. Neurophysiol.*, 20: 408-434.
- Stone, J. 1965 A quantitative analysis of the distribution of ganglion cells in the cat's retina. *J. Comp. Neur.*, 124: 337-352.
- Talbot, S. A., and W. H. Marshall 1941 Physiological studies on neural mechanisms of visual localization and discrimination. *Am. J. Ophthalm.*, 24: 1255-1263.
- Van Buren, J. M. 1963 *The Retinal Ganglion Cell Layer*. Charles C Thomas, Springfield, Ill.
- Wiesel, T. N. 1960 Receptive fields of ganglion cells in the cat's retina. *J. Physiol.*, 153: 583-594.